

DAVIDHARBER

EXTERIORS

CONTENTS

A Beguiling Nature	2
Dark Planet	4
Mantle	6
Torus	8
Armillary	10
Chalice	12
Matrix	14
Hydra	15
Bite	16
Creative Contrasts	18
Fire Vortex	20
Ways of Working	22
The Custom Commission	24
True to the Last Detail	26
Sculpture	27
Water Features	36
Water Walls	40
Sundials	42
Engravings & Etchings	48
Plinths	50
Installations	52
Eaton Square	54
Meet the Team	55
Next steps	56

DAVIDHARBER

EXTERIORS



DAVID HARBER

A BEGUILING NATURE

David Harber's creative approach to exterior sculpture is driven by the challenge of each site. He ensures that his artworks are appropriate for each location and often brings his signature playful curiosity and sense of dialogue to the fore. Using light and shadow, form and void, reflection and transparency – a David Harber piece will instil a sense of drama.

Inspired by nature in all its forms, a David Harber artwork makes a harmonious addition to any site. His pieces respond to their locations; reflecting foliage, creating places of quiet absorption and instilling awareness of their surroundings.

Sometimes using elements such as water and fire as part of a sculptural interplay, they complement the environment within which they stand.

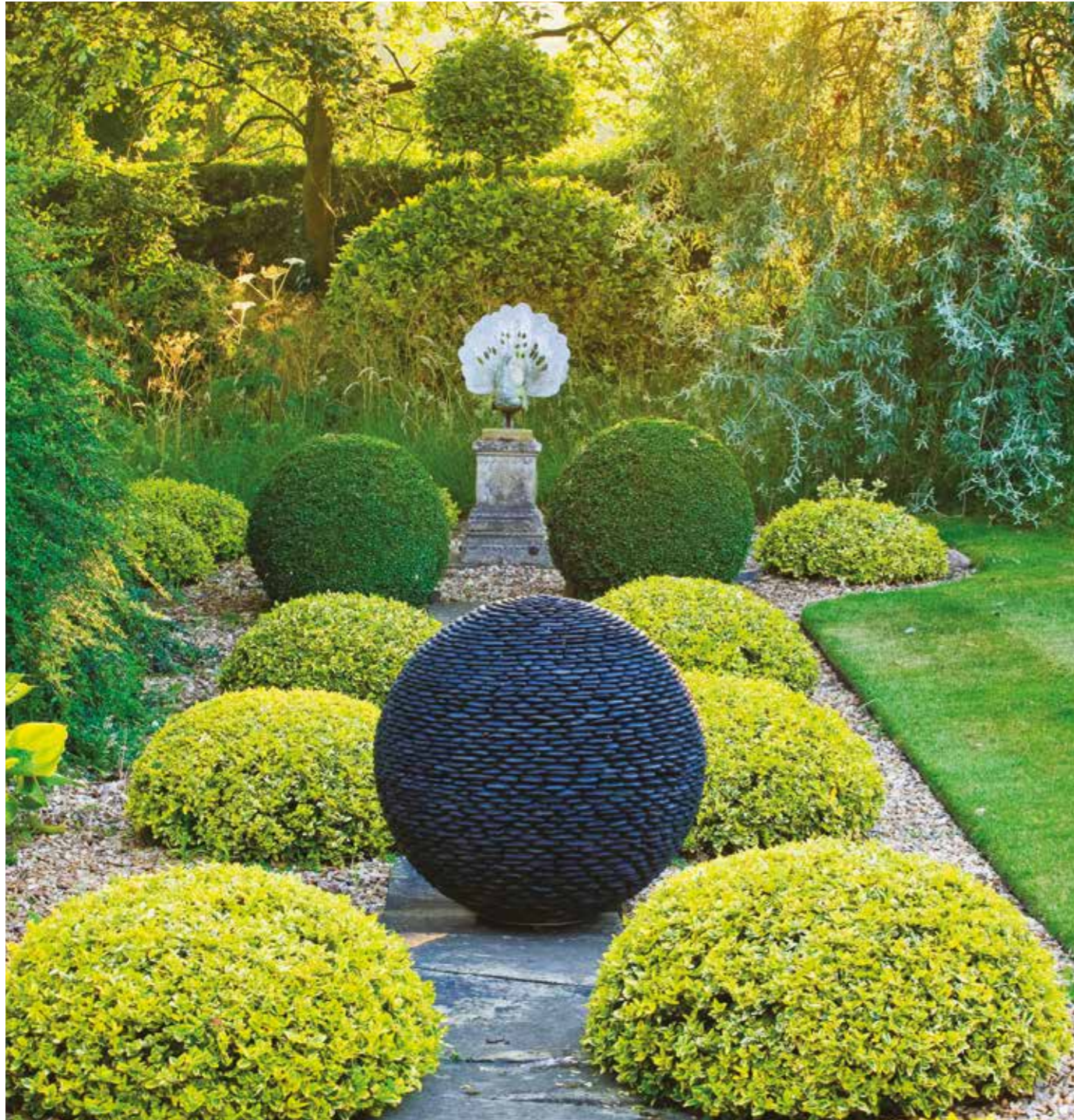

“I love to take rough ‘masculine’ elements and transform them into smooth sculptural surfaces.”

- DAVID HARBER

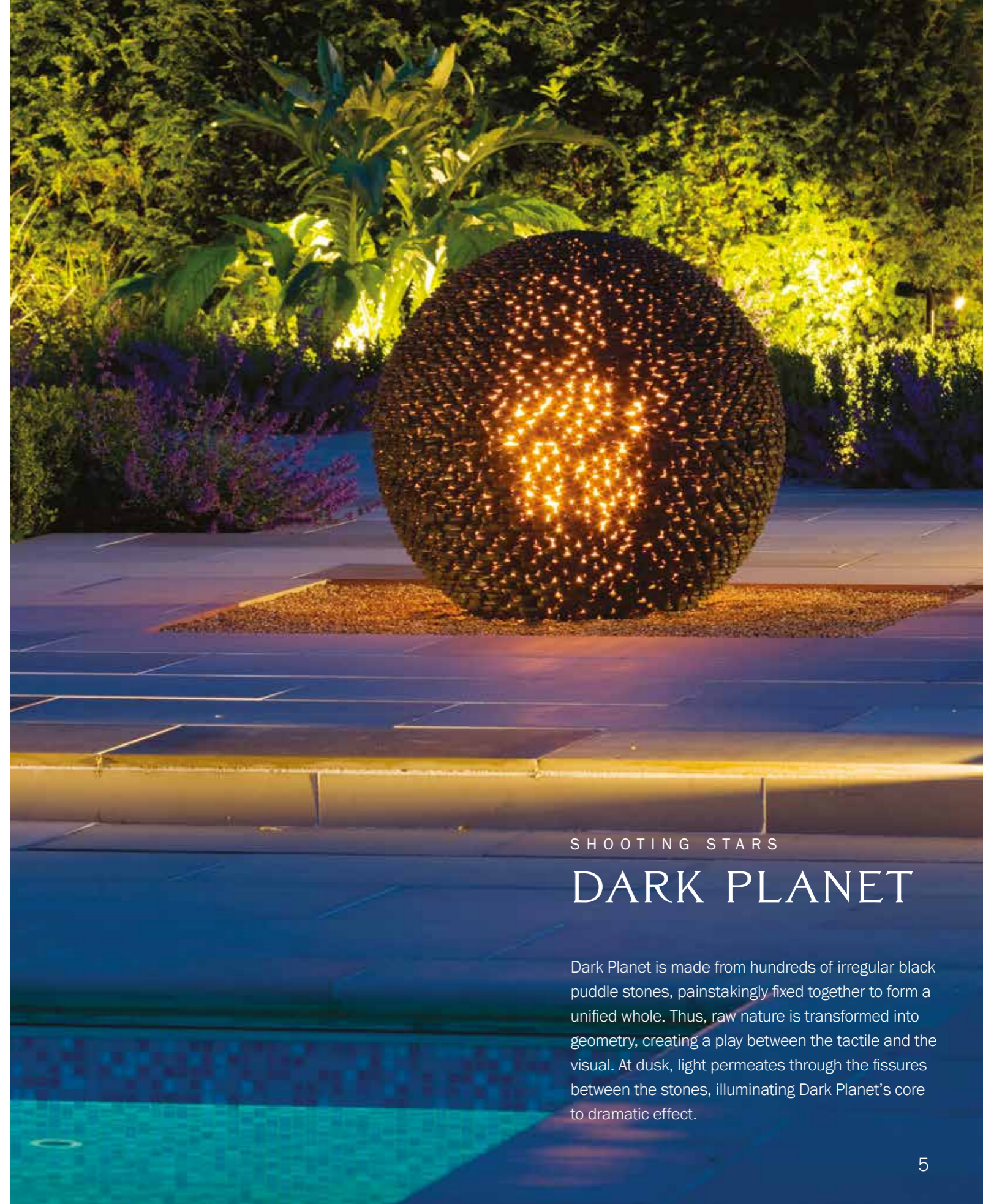

SHOOTING STARS

DARK PLANET

Dark Planet is made from hundreds of irregular black puddle stones, painstakingly fixed together to form a unified whole. Thus, raw nature is transformed into geometry, creating a play between the tactile and the visual. At dusk, light permeates through the fissures between the stones, illuminating Dark Planet's core to dramatic effect.



HARMONY AND MAGIC

MANTLE

Inspired by planet Earth, its intrigue lies in the tension between the wafer-thin crust and the golden interior – a metaphor for our eco-system. The Mantle is made of hundreds of bronze petals linked into a cellular latticework of turquoise verdigris. The underside of each leaf is gilded, giving the Mantle's interior an ethereal golden glow, as if suggesting an inner life force.

ENTICING ILLUSIONS

TORUS

Convex curves and a defining central void are the elements that make up Torus. Created in mirror-polished stainless steel, this sculpture mirrors its environment and provides a frame as if inviting the viewer to look through a portal to another world.





TIME AND EMOTION
ARMILLARY

Nearly two millennia ago, Ptolemy, the great Greco-Egyptian astronomer and mathematician, envisaged the armillary sphere as the model of spherical astronomy and the motions of the heavenly bodies. Today, David Harber's fascination with space and the solar system inspired him to create the astronomically intriguing Armillary.



ELEMENTAL AND ENCHANTING
CHALICE



The award-winning Chalice redefines the relationship between fixed and moving sculptural forms. With minute accuracy of design, flowing water clings to the Chalice's mirror-polished outer surface, creating the illusion of a stainless steel hemisphere slowly revolving on its axis. Illuminated, this sculpture is designed to be savoured by day and night.



SPATIAL VOLUMES

MATRIX

Space is all around us, and informs our passage in the world. The Matrix plays with the balance of negative and positive space, inviting us to look within as well as without. Made of a series of verdigris bronze hoops, the Matrix supports randomly placed inserts with gilded inner surfaces.



LYRICAL MOVEMENT

HYDRA

Light dances across the elegant Hydra, a small cluster of organic forms made of bronze that play together in the landscape, creating a sense of lyrical movement.



"I'm excited by the interplay of convex and concave surfaces and differing metals, textures and tones."

- DAVID HARBER



CORE VALUES

BITE

Within a copper sphere, three concave curves of mirror-polished stainless steel create reflective surfaces that draw the viewer in and reflect the surroundings. The seamless transition from a perfect sphere into parabolic mirror inlays creates a fascinating optical illusion.

EVOLUTION
CREATIVE CONTRASTS



Each David Harber artwork begins with an appraisal of the capability of selected materials and consideration as to their potential textures and tones. The Volante, for example, is a water feature with two wings of verdigris bronze set on either side of a recessed, mirror-polished stainless steel rill - creating an interplay between two distinct metals and the water that courses down the rill. Ever restless, Harber is developing a new Volante made of oxidised steel with a glass rill built up in layers of kiln-formed coloured glass. The effect is to create a dramatic interaction between the opacity of metal, the transparency of glass, and the movement of water.



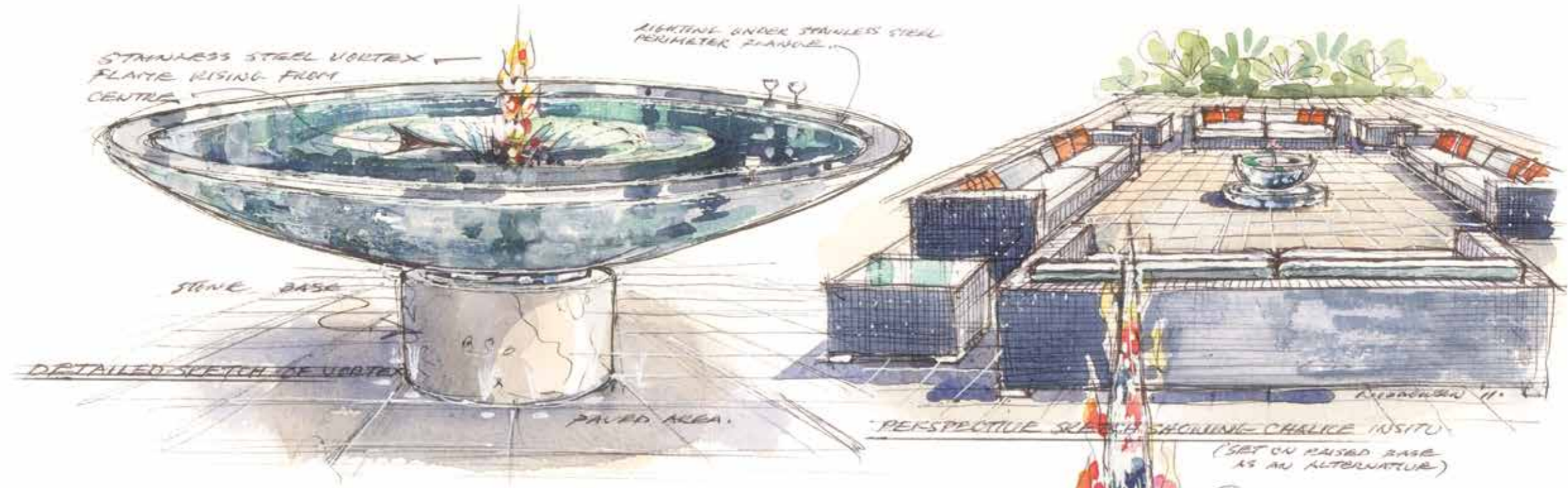

DETAILED SKETCH OF VORTEX

INNOVATION
FIRE VORTEX

The elements – fire, water, air, earth – are all vital subject matter, to be used as part of sculpture. In this piece a mirror-polished concave dish is spun with water from the perimeter to the centre, highlighting a flame that dances up through the falling water, casting its reflection. With a halo of light emanating from the perimeter and illuminating the water in the bowl, the Fire Vortex commands all the elements.

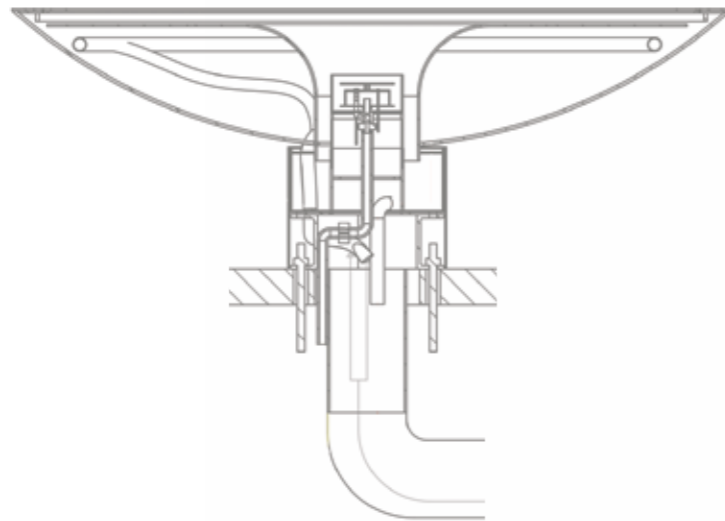

DETAILED SKETCH OF CHALICE (SAT DIRECT ONTO FLOOR)

CHALICE BY DAVID HARBER

WAYS OF WORKING

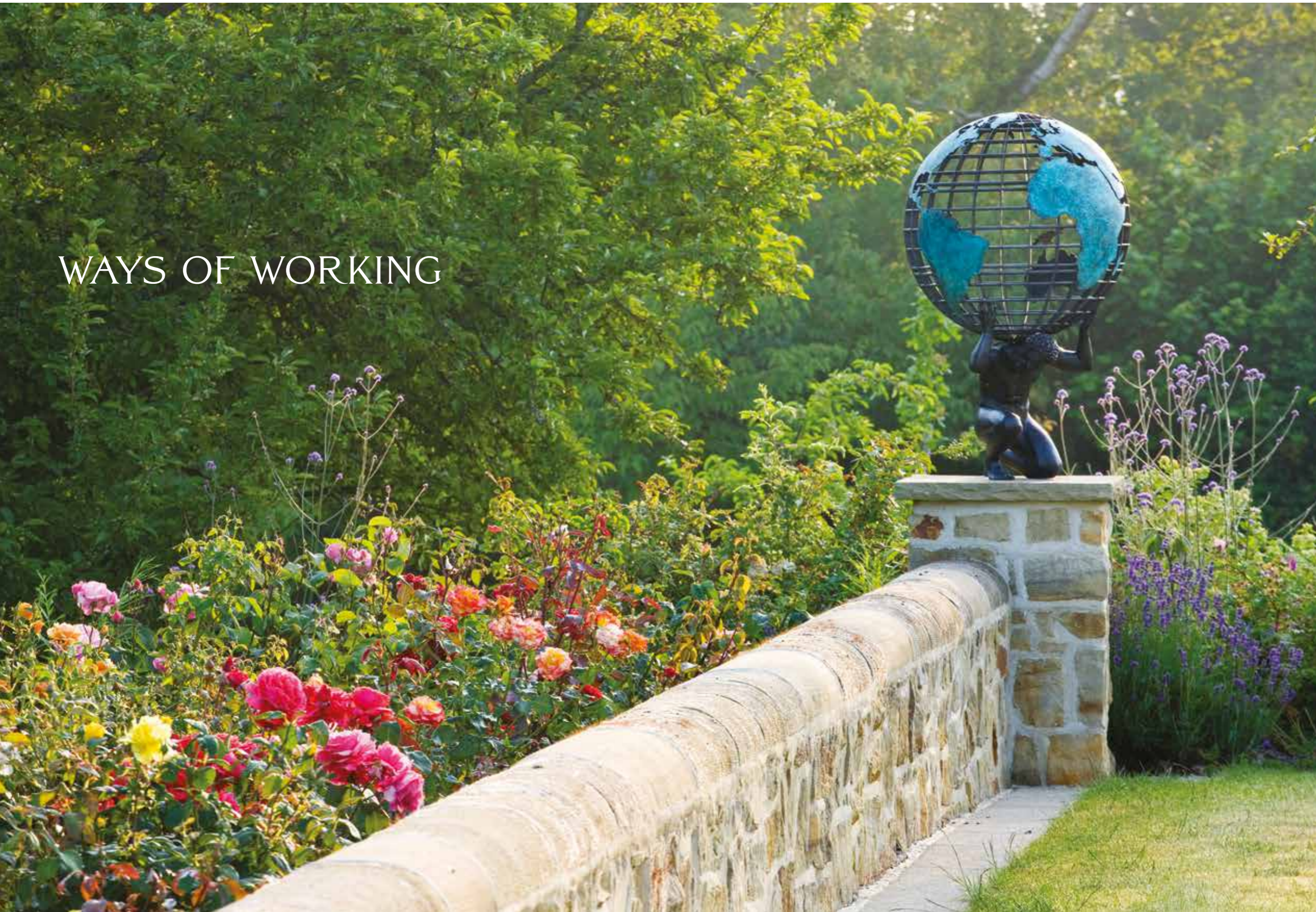

THE BESPOKE COMMISSION

Commissioning a bespoke David Harber piece offers you direct access to David's dedicated attention and artistic creativity. Capturing the essence of a space, David personally supports each client through the journey, helping them to shape their vision and using his experience to ask the most important questions about the artwork, creating a dynamic process and fully engaging with each client. David will spend time overseeing the project from initial site visits and concept sketches to shortlisted designs and working drawings – right through to the creation of the sculpture and its ultimate installation.

A BESPOKE COMMISSION – ATLAS GLOBE

A fine example of a bespoke commission is the Atlas Globe, designed by David Harber for the owner of a large international travel business with clients worldwide, as a way to embody his business and his love of travel.



THE CUSTOM COMMISSION

The custom commission is another way of acquiring a David Harber artwork and offers a simpler approach than a bespoke one-off commission. This route involves adding your own imprint to an existing David Harber design, by changing the materials, size, finishes, etching and engraving – providing countless combinations that will make it unique.

A CUSTOM SCULPTURE – WATER MANTLE

A customised design where the Mantle artwork – which is normally dry – was transformed into a powerful water feature.



TRUE TO THE LAST DETAIL

To ensure that each of our clients can get exactly what they want, David Harber's artworks are available in a wide range of sizes, materials and finishes. Should your requirements go beyond this level of customisation, David is always delighted to discuss ideas for an original, bespoke commission.

SCULPTURE



1. Bud – Designed for a plinth, it is made from bronze 'leaves' to form a bud-like shape; the front view is open to expose a mirror-polished stainless steel stamen-like element. Height 100cm, width 80cm, depth 110cm.

2. Coluna – A simple fluid sculpture, Coluna is made of copper discs in varying diameters, supported on a mirror-polished stainless steel tube anchored at both ends. It can be tailored to fit almost any setting. Length 237cm, height 112cm.

3. Eveque – A trio of bronze and stainless steel elements that interact to form a single arch, appearing to split and re-assemble as you view it in the round. At night, Eveque is illuminated through its fretwork windows. Height 198cm, width 83cm, depth 68cm.



SCULPTURE



1. Portal – Made of interwoven oxidised steel and mirror-polished stainless steel, Portal's organic design evokes nature. Diameters available: 160cm, 200cm, 240cm.

2. Bite – This copper sphere has three inlaid concave stainless steel parabolic mirrors. Also available in Corten and stainless steel. Diameter 90cm.

3. Dark Planet – This smooth, tactile sphere made of polished puddle stones is transformed after dark by a subtle inner light. Diameters available: 76cm, 100cm, 120cm, 160cm.

4. Hydra – A slender and elegant tree-like sculpture, made in bronze (clients have a choice of oxidised or verdigris patina). Hydra allows lines of poetry to be added along two of its branches. LED lighting incorporated. Height 220cm.

5. Dark Planet (slate) – This time created using hundreds of Welsh slate pieces to form a perfect sphere. Transformed after dark by a subtle inner light. Diameters available: 76cm, 100cm, 120cm, 160cm.

SCULPTURE



1. Quill (bronze) – Made of a delicate lattice of verdigris bronze petals internally gilded with 23¾-carat gold leaf, the Quill has an internal LED that creates a lantern-like effect by night. Heights available: 180cm, 200cm, 240cm, 300cm.

2. Quill (stainless steel) – Made of elongated brushed stainless steel petals interspersed with some that are mirror-polished, the Quill has an internal LED that creates a lantern-like effect by night. Heights available: 180cm, 200cm, 240cm, 300cm.

3. Hammanim – A mirror-polished stainless and oxidised steel monolith. At night slits in the oxidised steel emit light, and the aperture at the top can incorporate an Analematic dial. Height 300cm.

4. Quill (oxidised) – Made of a delicate lattice of oxidised steel petals, the Quill has an internal LED that creates a lantern-like effect by night. Heights available: 180cm, 200cm, 240cm, 300cm.

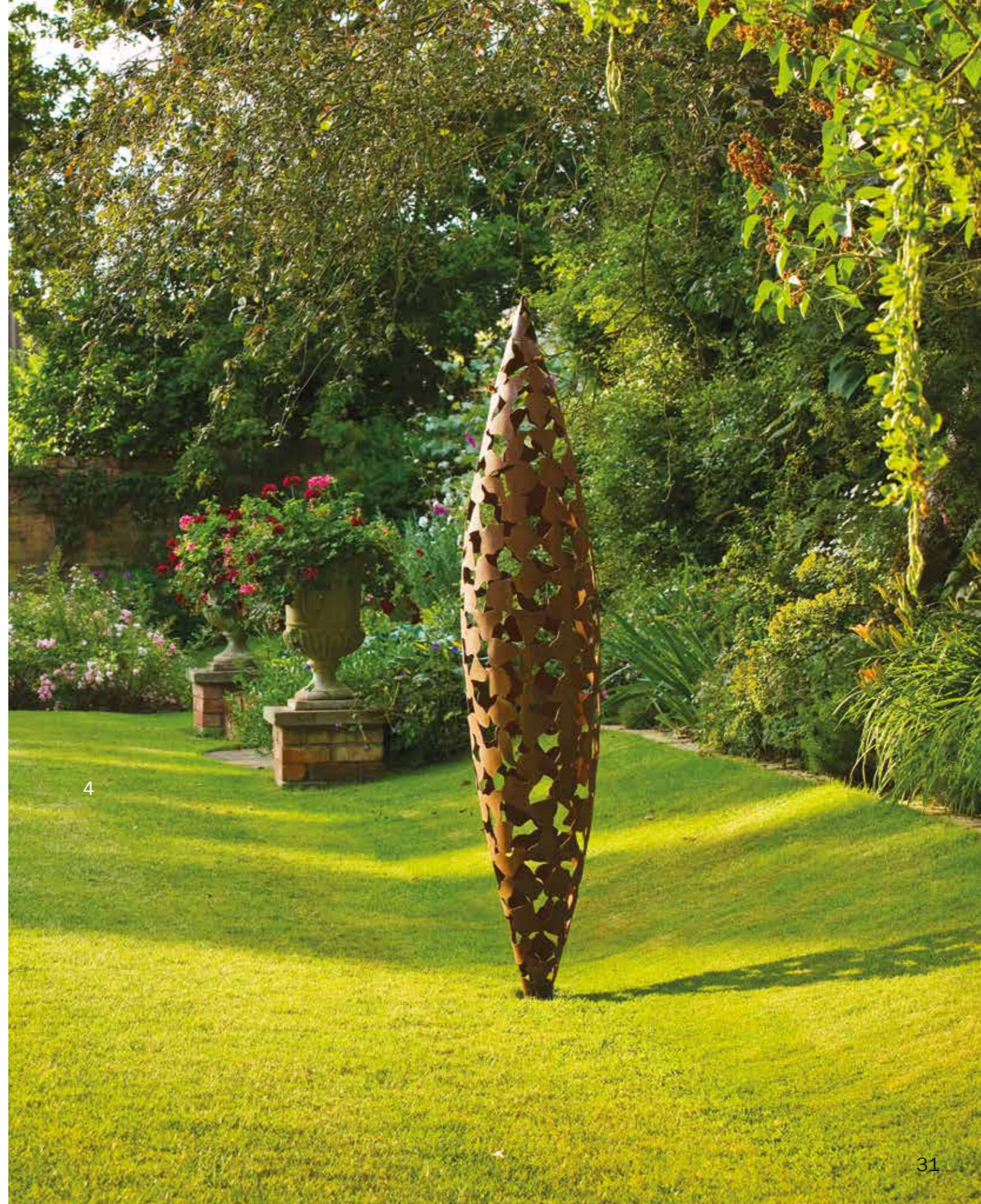



SCULPTURE



1. Kernel – This polished stone sphere has a mirror-polished stainless steel wedge cut into it, revealing a shiny core surrounded by oxidised steel. Transformed after dark by a subtle inner light. Diameters available: 76cm, 100cm, 120cm, 160cm.

2. Mantle – Made of verdigris bronze petals with 23³/₄-carat gold leaf on their inner faces. An internal light transforms it into a breathtaking feature at night. Also available in Corten and mirror-polished stainless steel. Diameters available: 50cm, 76cm, 100cm, 120cm, 160cm. This is a limited-edition piece.

3. Matrix – A series of bronze hoops supporting randomly placed reflective plates, with their inner surfaces gilded in 23³/₄-carat gold leaf. Diameters available: 76cm, 100cm, 120cm, 160cm.

4. Sky Planets – This pair of Dark Planets exposes two stainless steel sky mirrors around a central oxidised nut. Can be commissioned as a pair or alone. Diameter 100cm.



SCULPTURE



Torus – Convex curves and knife-edge seams combine with a central ‘portal’ hole to contrast and connect to the natural environment. LED lighting incorporated. All variations available in these diameters: 100cm, 150cm, 180cm, 200cm, 230cm, 240cm.

1. Stainless Steel – Brilliant mirror-polished stainless steel on both sides.

2. Stainless Steel and Slate – One side is formed from heather-blue slate.

3. Stainless Steel & Cotswold Stone – One side is formed from Cotswold stone.

4. Stainless Steel and Terracotta – One side is formed from warm-toned terracotta.

WATER FEATURES



1. Chalice – Made of two mirror-polished stainless steel hemispheres, water overflows from the Chalice’s outer rim and, via surface tension, continues to conform to its side. Chalice is lit both internally and from below with either blue or white LEDs. Diameters available: 76cm, 100cm, 120cm, 150cm, 200cm.

2. Ekho – A classical bronze verdigris bowl, Ekho has a 23¾-carat gold-leaf waterline. LED lighting incorporated. Diameter 88cm. Its water effect can be a single fine jet or a ripple.

3. Mimeo – A bronze dish with a Moorish-influenced filigree pattern cut into its inner and outer edges. Its water effect can be a single fine jet or a ripple. LED lighting incorporated. Diameter 86cm.

4. Crucello – A contemporary variation of a three-tiered fountain, Crucello is made from verdigris bronze and creates the entrancing effect of surrounding each tier with a veil of water. It can adorn an existing pool or David Harbor can produce a tank to suit. LED lighting can be incorporated. Diameter 120cm, height 185cm.





1

WATER FEATURES

1. Volante – Two wings of verdigris bronze sit either side of a recessed mirror-polished stainless steel vertical rill, down which water courses. Volante is supported on a stainless steel tank. LED lighting incorporated. Height 130cm. Also available in oxidized steel and kiln-formed glass.

2. Dark Planet Fountain – Water cascades gently over dark pebble stones, grouted within to provide a waterproof membrane. Tank included. Diameters available: 76cm, 100cm, 120cm, 160cm.



2



3



4



5

3. Ether Mirage – A combination of the Chalice and a series of Ether spheres made of horizontal mirror-polished wafers. LED lighting incorporated. Height 240cm, diameter 100cm.

4. Water Obelisk – This classical obelisk reflects its immediate surroundings via a film of water that shimmers down its four mirror-polished faces. Tank included. Height 215cm.

5. Vortex – Water spirals down a shallow crucible of mirror-polished stainless steel, enhanced at night by LED lighting. Can be mounted on a stone plinth. Diameter 80cm.

WATER WALLS



1



2



3

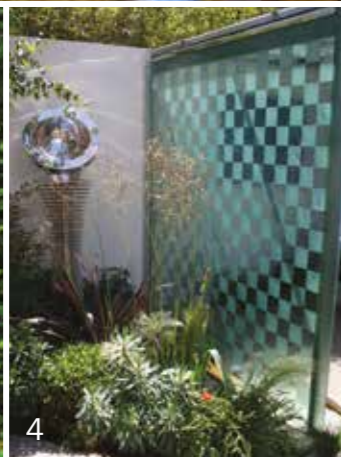

4



5

While it depends to a degree on the material and design chosen, our water walls can be made to almost any height or width. Reservoir tanks can be above or below ground. Lighting which enhances the effect at night, the pump and the reservoir tank are all included.

1. Waves – This water wall is made from mirror-polished stainless steel with verdigris bronze waves set into the surface and held by a bronze frame.

2. Petal – Made from hundreds of scale-shaped, mirror-polished stainless steel petals.

3. Interwoven – Mirror-polished stainless steel and oxidised steel are combined to create an interwoven, textural pattern.

4. Glass – A contemporary glass water wall made from clear or coloured glass, which can be etched with any pattern or wording. Available with or without a stainless steel frame.

5. Stainless Steel – A simple mirror-polished stainless steel water wall can create real impact in a garden.

6. Filagree – A framed Verdigris bronze design, behind which water flows over a mirror-polished stainless steel surface.



6

SUNDIALS



ARMILLARY SPHERES

All spheres available in these diameters: 50cm, 60cm, 70cm, 80cm, 90cm, 100cm.

These additional features are already incorporated into the bronze armillary sphere and can be added to the brass and stainless steel versions:

- Extra rings marking the Tropics of Capricorn and Cancer and the North and South Polar Circles
- A calendar showing the progression of the months and a client-specified date
- Arrowhead and tail

Dials can be engraved with words and phrases of personal resonance, such as mottoes and quotations; family names and dates of birth; commissioning statements; house names with latitude and longitude; and the distances and direction to locations significant to the client.

1. Bronze – As well as being strong and highly durable, a bronze verdigris patina gives the impression of timelessness. Our bronze dials come with Tropics, Polar Circles, calendar and arrowhead and tail fitted as standard.

2. Stainless Steel – Made from marine-grade stainless steel, these dials are mirror-polished to ensure high visibility and lifelong brilliance.

3. Brass – A lighter material than bronze, brass has a real sense of weight and a patina that matures well, darkening with age.

SUNDIALS



1. Atlas – A bronze cast of Atlas supporting a simple personalised brass armillary sphere. Atlas height 57cm, sphere diameter 70cm.

2. Globe Dial (copper) – This 16th-century design can either be a sun or a moon dial. The hinged crescent is moved until the shadow is directly underneath, and the time read against the hours engraved or etched onto the surface of the globe. Diameters available: 50cm, 70cm.

3. Berosus Dial – The copper or stainless steel dial is inclined to its latitude. Hour lines, hour markers and dial furniture are all hand engraved or etched onto the inner hemisphere. Diameters available: 50cm, 60cm.



1

SUNDIALS



2



3



4

1. Light Sorceress – Each figure is individually designed and sculpted from verdigris copper. Depending on the orientation and location, the Light Sorceress can either hold a glass vertical dial or a mirror disc etched with a poem. Height 158cm, glass diameter 60cm.

2. Horizontal Dial – Available in brass, bronze, stainless steel or stone, the classical horizontal dial can be made to any size and enhanced with a wide range of options for personalisation.

3. HMS Victory – A horizontal dial that features copper recovered from the original hull of HMS Victory, authenticated by the Royal Navy. Engraved on the dial are the key events of the Battle of Trafalgar including Nelson's famous signal: 'England expects every man to do his duty'. Diameter 55cm.

4. Maya Dial – This David Harber innovation creates an optical illusion of a solid, free-floating central sphere. The dial comprises 24 stainless steel crescents, an hour band and rings to represent the Tropics of Cancer and Capricorn. Diameter 60cm.

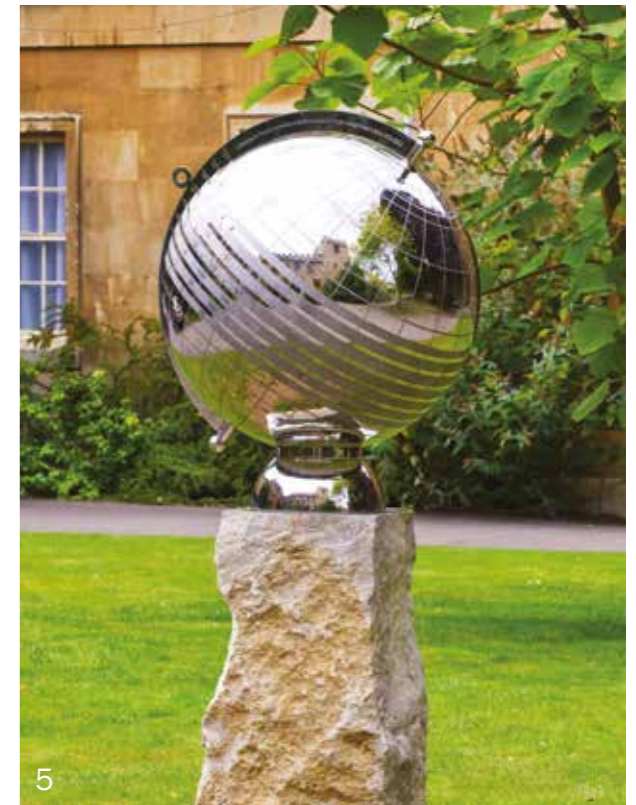

5

5. Globe Dial (stainless steel) – This 16th-century design can either be a sun or a moon dial. The hinged crescent is moved until the shadow is directly underneath, and the time read against the hours engraved or etched onto the surface of the globe. Diameters available: 50cm, 70cm.



1

OBELISK

The length of the shadow cast by the obelisk at noon can be calculated and shown with markers set into the ground. Standard markers indicate the spring and autumn equinoxes, winter and summer solstices, and can also highlight birthdays or other significant dates.

1. Stainless Steel – The marine-grade mirror-polished stainless steel used on this dial both catches the eye and reflects its surroundings. Heights available: 210cm, 250cm, 300cm.

2. Copper – This subtle and intriguing material matures well and darkens over time. Heights available: 210cm, 250cm, 300cm.

3. Stainless Steel and Slate – A mixed-material version of the obelisk, made from heather-blue slate and finished with a mirror-polished frame. Heights available: 210cm, 250cm, 300cm.



2



3

SUNDIALS



VERTICAL DIALS

1. Copper – The face of the dial can be sign-written in 23 $\frac{3}{4}$ -carat gold leaf, contrasting wonderfully with the verdigris patina of the copper.

2. Enamel – The stainless steel base can be industrially enamelled in any colour you wish. The dial furniture is then sign-written by hand.

3. Hand-painted – These dials can either be painted directly onto a rendered surface on the house or onto a panel that is then fixed to a wall.

4. Lead – This smooth material can be sign-written in 23 $\frac{3}{4}$ -carat gold leaf and the surface either oiled to maintain a dark colour or left to oxidise to a silver finish.

5. Noon Day Analemma – Developed by the Moors around 600BC, this dial has a figure-of-eight showing the months of the year. The gnomon casts a shadow that tracks noon throughout the year.

6. Slate – Either riven or smooth, the slate is letter-cut by hand and gilded with 23 $\frac{3}{4}$ -carat gold leaf.

7. Stone – Any hard stone can be used, letter-cut by hand and typically filled with 23 $\frac{3}{4}$ -carat gold leaf. We can source the right stone to match your wall.

8. Strip – Specially developed by David Harber, these dials comprise strips of bronze, brass, copper or stainless steel fixed directly onto the surface of the wall. The numerals and dial furniture are then laser-cut to match.



ENGRAVINGS AND ETCHINGS

Each commission can be personalised through engraving or etching. The armillary sphere in particular has the potential for extensive engraving, including mottoes or lines of poetry; family names and dates of birth; commissioning statements; house names with latitude and longitude; and distances and bearings in nautical miles for up to five locations of personal significance.

David Harber delights in engraving and etching, as it makes a commission a much more intimate and personal process. For example, a Mantle or Quill can incorporate a few words on a discreetly located petal.

PLINTHS

Natural Boulder – A Purbeck stone boulder. Available in any height or size, boulders usually require additional manpower for installation.

Purbeck Stone – A simple design with a rough-punched or honed finish. Heights available: 80–90cm, top 26cm, base 31cm.

Small Staddle Stone – A rough-chiselled plinth in sandstone. Overall height 80cm, top 25cm, base 44cm. The stone sits on a separate chamfered square base 53cm.

Large Staddle Stone – A rough-chiselled plinth made from sandstone. Height 92cm, top 26cm, base 44cm.



Square Pedestal – A classical hand-cut sandstone plinth. Height 85cm, top 38cm, base 38cm.

Antique Reproduction Plinth – Made of natural stone, these are hand cut to mimic classical antique plinths. Height 90cm, top 33cm, base 33cm.

Black Staddlestone – A classical plinth made from a contemporary black granite. Height 86cm, top 25cm, base 30cm.

Reconstituted Cast Stone – Available in an enormous range of designs, sizes and colours. Our recommended supplier is Haddonstone Ltd.

INSTALLATIONS

All UK mainland commissions are personally delivered and securely installed by our workshop staff and include alignment, calibration and other mechanical fine-tuning. In cases where you may need to provide additional personnel on site (for example, a qualified electrician) we will advise you well in advance.

For overseas installations we have a wealth of experience in packaging, shipping and then coordinating the installations in far-flung places. Our careful planning and meticulous attention to detail is paramount when working on such projects.

SECURITY

We take considerable care to ensure that each commission is appropriately and securely fixed in position. Additional measures can be provided for sites where security is of particular concern.

ELECTRICITY

To comply with current legislation, all permanent on-site electrical connections must be made by your own NICEIC or equivalently qualified electrician.

FILTRATION

To maintain optimum performance for our water features, we strongly recommend including one of our customised filtration packages and carrying out regular maintenance. In the UK, if you require a maintenance service our recommended supplier is Aquajoy Water Gardens Ltd who will be happy to provide you with an estimate.

AFTERCARE

All David Harber installations are built to stand the test of time, whether indoors or out in the open, and in most cases require minimal aftercare support.





EATON SQUARE, LONDON

Our semi-permanent exhibition in the private gardens of Eaton Square, SW1 offers those who happen to be in London the chance to see first hand a range of designs displayed in a gracious city setting. It is the perfect place

both for designers to show clients and for clients to view the works by appointment. If you would like to visit the gardens just contact us to arrange a time.



MEET THE TEAM

Each David Harber commission involves a dedicated team, who guide it through the whole process and advise on all the aesthetic and technical aspects from production, to finishing and full quality control.

We work directly with clients, or in collaboration with designers, contractors, consultants and project managers. Day-to-day client and contractor liaison is an important part of the process to ensure a successful and enjoyable path between commissioning and completion.

We welcome clients to our Oxfordshire workshop either at the critical early planning stage of a commission or perhaps to look at your own commission being made.

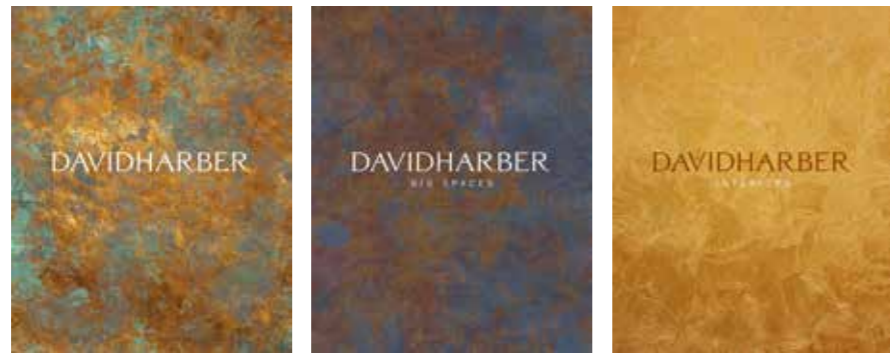

NEXT STEPS

To make an appointment at our studio and workshop, to arrange a site visit
or to discuss your project, please contact us on

+44 (0)1235 859300
or at sales@davidharber.com

Photography: Cinnamon Andrews, Oliver Edwards, Bruce Harber, Clive Nichols, Paul Ridley
Design: Zeke Creative Ltd

DAVID HARBER LTD

Blewburton Barns, Hagbourne Road, Aston Upthorpe
Oxfordshire OX11 9EE England

+44 (0)1235 859300
sales@ davidharber.com

www.davidharber.com